

XEF 1.9 Factory

Variante colore:
white



Colore: **military green**

Specifiche tecniche



Aluminum, sizes: S - M - L



SunRace SilverRed, 12V, 11-51



Brose S-Mag 36,
Torque/Coppia: 90 Nm



Braking IN.CA.S disc brake



Fantic, Lithium Ion, 36 Volt, 720Wh



Mavic E-Deemax 29" - 27.5"



RockShox Zeb Ultimate 190mm



Vittoria E-Mazza
Vittoria E-Martello



Ohlins TTX 22M



Selle Italia Novus Boost
X Cross Superflow

(*) FANTIC MOTOR si riserva il diritto di modificare le caratteristiche tecniche elencate, senza alcun obbligo di preavviso.
Tutte le immagini sono inserite a scopo illustrativo. I prodotti possono subire modifiche.



(*) FANTIC MOTOR si riserva il diritto di modificare le caratteristiche tecniche elencate, senza alcun obbligo di preavviso. Tutte le immagini sono inserite a scopo illustrativo. I prodotti possono subire modifiche.

XEF 1.9 Factory

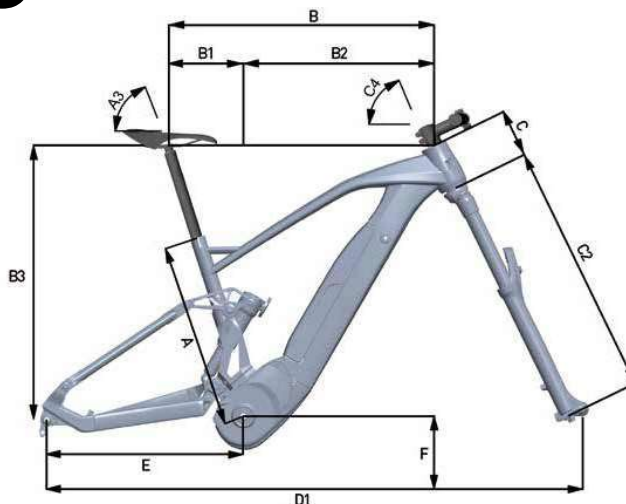

| | |
|-------------------------|--|
| Motore | Brose S-Mag 36, Torque/Coppia: 90 Nm |
| Batteria | Fantic, Lithium Ion, 36 Volt, 720Wh |
| Display | Brose Remote |
| Telaio | Aluminum, sizes: S - M - L |
| Forcella | RockShox Zeb Ultimate 190mm |
| Ammortizzatore | Ohlins TTX 22M |
| Corona | Sram 34t |
| Pedivelle | FSA |
| Deragliatore | Sram GX AXS |
| Comandi cambio | Sram GX AXS Eagle |
| Cassetta | SunRace SilverRed, 12V, 11-51 |
| Catena | Sram NX |
| Freno ant. | Braking IN.CA.S disc brake |
| Freno post. | Braking IN.CA.S disc brake |
| Disco ant. | Braking S3 Battfly, 220mm - 6Hole |
| Disco post. | Braking S3 Battfly, 203mm - 6Hole |
| Pneumatici ant. | Vittoria E-Mazza 29"x 2.6 |
| Pneumatici post. | Vittoria E-Martello 27,5"x 2.8 |
| Ruote | Mavic E-Deemax 29"- 27.5" |
| Manubrio | Fantic Racing-800mm- Ø35 - Rise 20mm -Sand |
| Attacco manubrio | Fantic Racing-35mm- Ø35 |
| Reggisella | Crankbrothers HIGHLIGHT7 Ø 30.9 |
| Sella | Selle Italia Novus Boost X Cross Superflow |
| Note | (*) |

| Misure | S | M | L |
|-----------|-------|-------|--------|
| A | 390 | 430 | 490 |
| A3 | 73 | 73 | 73 |
| B | 586 | 596 | 628 |
| B1 | 161 | 162 | 166 |
| B2 | 425 | 454 | 480 |
| B3 | 617,8 | 622,0 | 633,7 |
| C | 105 | 110 | 120 |
| C2 | 581 | 581 | 581 |
| C4 | 65 | 65 | 65,5 |
| D1 | 1241 | 1245 | 1270,5 |
| E | 459 | 459 | 459 |
| F | 363,5 | 363,5 | 363,5 |

(*) FANTIC MOTOR si riserva il diritto di modificare le caratteristiche tecniche elencate, senza alcun obbligo di preavviso. Tutte le immagini sono inserite a scopo illustrativo. I prodotti possono subire modifiche.



@fanticbikes



Fantic Bikes



Fantic Bikes



Fantic Motor



@fanticmotor_official

fantic.com

FANTIC

Fantic,
disegniamo,
progettiamo
ed assembliamo
bici elettriche
ad alte
prestazioni.

Fantic Motor S.P.A.
Via Tarantelli, 7
31030 Dossan di Casier (TV) Italy
info@fanticmotor.it
fantic.com