

# Living



Farbe: **sand**

## Technische Daten



Aluminium, sizes: S - M - L



Promax Solve ST 925 hydraulic 2P,  
180mm disc



Yamaha PW S2,  
Torque/Coppia: 75Nm



GBC 29"



Fantic, Lithium Ion, 36 Volt, 630Wh



Vittoria E-Randonneur



Suntour XCR34, travel 100mm



Selle Italia S5 Superflow



Sram SX, 12V, 11-50

(\*) FANTIC MOTOR behält sich das Recht vor, technische Eigenschaften ohne vorherige Ankündigung zu ändern.  
Änderungen der Produkte sind vorbehalten.



Index



(\*) FANTIC MOTOR behält sich das Recht vor, technische Eigenschaften ohne vorherige Ankündigung zu ändern. Änderungen der Produkte sind vorbehalten.

# Living

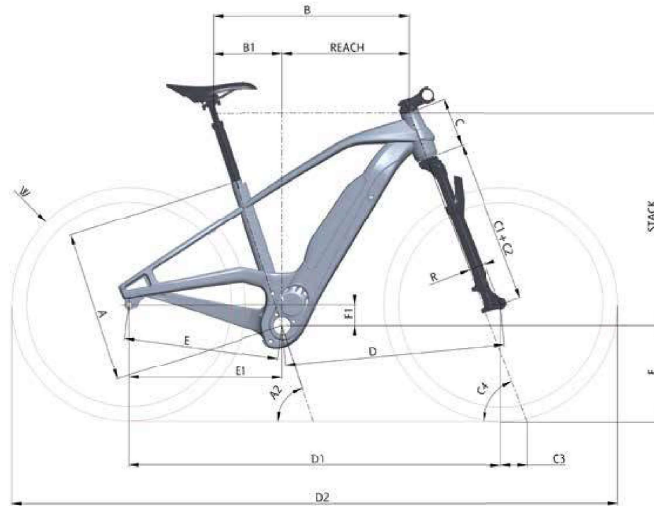

<b>Motor</b>	Yamaha PW S2, Torque/Coppia: 75Nm
<b>Batterie</b>	Fantic, Lithium Ion, 36 Volt, 630Wh
<b>Display</b>	Display B Yamaha
<b>Rahmen</b>	Aluminium, sizes: S - M - L
<b>Gabel</b>	Suntour XCR34, travel 100mm
<b>Fahrrad kurbel</b>	FSA
<b>Schaltung</b>	Sram SX Eagle
<b>Schaltkassette</b>	Sram SX, 12V, 11-50
<b>Kette</b>	Sram SX
<b>Vorderradbremse</b>	Promax Solve ST 925 hydraulic 2P, 180mm disc
<b>Hinterradbremse</b>	Promax Solve ST 925 hydraulic 2P, 180mm disc
<b>Reifen</b>	Vittoria E-Randonneur
<b>Felgen und Speichen</b>	GBC 29"
<b>Vorderradnabe</b>	GBC, 110mm Boost
<b>Hinterradnabe</b>	GBC, 148mm Boost
<b>Lenker</b>	GBC 700mm, Rise 20mm
<b>Vorbau</b>	GBC 70mm
<b>Sattel</b>	Selle Italia S5 Superflow
<b>Sattelstütze</b>	Promax Suspended Ø30.9
<b>Griffe</b>	Urban Gist
<b>Pedale</b>	Aluminium
<b>Vordere lampe</b>	Busch Muller
<b>Rücklicht</b>	Trelock
<b>Vorhängeschloss</b>	Abus
<b>Bemerkung</b>	(*)

Maßnahmen	S	M	L
<b>A</b>	430	460	495
<b>A2</b>	72	72	72
<b>B</b>	575	600	620
<b>B1</b>	204	201	216
<b>Reach</b>	371	399	404
<b>Stack</b>	628	618	665
<b>W</b>	28"	28"	28"
<b>C</b>	130	150	170
<b>C1</b>	2	2	2
<b>C2</b>	490	460	490
<b>C3 Trail</b>	92,6	92,2	92,6
<b>C4</b>	69	69	69
<b>R</b>	44	44	44
<b>D</b>	638	662	685
<b>D1</b>	1102	1126	1149
<b>D2</b>	1830	1854	1877
<b>E</b>	471	471,2	471
<b>E1</b>	467	467	467
<b>F</b>	301	301	301
<b>F1</b>	63	63	63
<b>Lever</b>	170	170	170
<b>Stem</b>	70	100	70
<b>Bar</b>	700	700	700
<b>Regg.</b>	350	350	350

(\*) FANTIC MOTOR behält sich das Recht vor, technische Eigenschaften ohne vorherige Ankündigung zu ändern. Änderungen der Produkte sind vorbehalten.



**@fanticbikes**



**Fantic Bikes**



**Fantic Bikes**



**Fantic Motor**



**@fanticmotor\_official**

**fantic.com**

**FANTIC**

**Fantic:**  
**Wir entwerfen,  
entwickeln  
und montieren  
leistungsstarke  
Elektrofahrräder.**

Fantic Motor S.P.A.  
Via Tarantelli, 7  
31030 Dossan di Casier (TV) **Italy**  
info@fanticmotor.it  
**fantic.com**