

Living



Couleur: **sand**

Fiches techniques



Aluminium, sizes: S - M - L



Promax Solve ST 925 hydraulic 2P,
180mm disc



Yamaha PW S2,
Torque/Coppia: 75Nm



GBC 29"



Fantic, Lithium Ion, 36 Volt, 630Wh



Vittoria E-Randonneur



Suntour XCR34, travel 100mm



Selle Italia S5 Superflow



Sram SX, 12V, 11-50

(*) FANTIC MOTOR se réserve le droit de modifier les caractéristiques techniques énumérées, sans aucune obligation de préavis.
Toutes les images sont incluses à des fins d'illustration. Les produits sont susceptibles d'être modifiés.





(*) FANTIC MOTOR se réserve le droit de modifier les caractéristiques techniques énumérées, sans aucune obligation de préavis. Toutes les images sont incluses à des fins d'illustration. Les produits sont susceptibles d'être modifiés.

Living

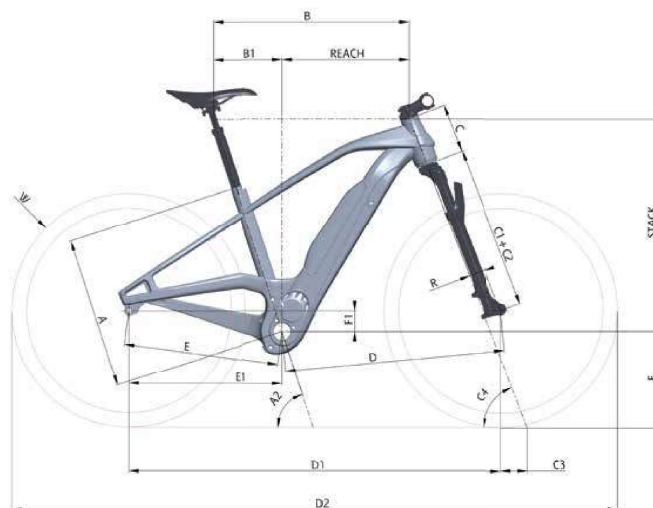

Moteur	Yamaha PW S2, Torque/Coppia: 75Nm
Batterie	Fantic, Lithium Ion, 36 Volt, 630Wh
Display	Display B Yamaha
Cadre & Tailles	Aluminium, sizes: S - M - L
Fourche	Suntour XCR34, travel 100mm
Pédalier	FSA
Groupe	Sram SX Eagle
Cassette	Sram SX, 12V, 11-50
Chaîne	Sram SX
Freins avant	Promax Solve ST 925 hydraulic 2P, 180mm disc
Freins arrière	Promax Solve ST 925 hydraulic 2P, 180mm disc
Pneus	Vittoria E-Randonneur
Jantes & Rayons	GBC 29"
Moyeux avt	GBC, 110mm Boost
Moyeux arr	GBC, 148mm Boost
Guidon	GBC 700mm, Rise 20mm
Potence	GBC 70mm
Selle	Selle Italia S5 Superflow
Tige de selle	Promax Suspended Ø30.9
Poignées	Urban Gist
Pédales	Aluminium
Feu avant	Busch Muller
Feu arrière	Trelock
Cadenas	Abus
Annotation	(*)

Mesures	S	M	L
A	430	460	495
A2	72	72	72
B	575	600	620
B1	204	201	216
Reach	371	399	404
Stack	628	618	665
W	28"	28"	28"
C	130	150	170
C1	2	2	2
C2	490	460	490
C3 Trail	92,6	92,2	92,6
C4	69	69	69
R	44	44	44
D	638	662	685
D1	1102	1126	1149
D2	1830	1854	1877
E	471	471,2	471
E1	467	467	467
F	301	301	301
F1	63	63	63
Lever	170	170	170
Stem	70	100	70
Bar	700	700	700
Regg.	350	350	350

(*)FANTIC MOTOR se réserve le droit de modifier les caractéristiques techniques énumérées, sans aucune obligation de préavis. Toutes les images sont incluses à des fins d'illustration. Les produits sont susceptibles d'être modifiés.



@fanticbikes



Fantic Bikes



Fantic Bikes



Fantic Motor



@fanticmotor_official

fantic.com

FANTIC

Fantic,
nous concevons,
réalisons et
assemblons
des vélos
électriques
à haute
performance.

Fantic Motor S.P.A.
Via Tarantelli, 7
31030 Dossan di Casier (TV) Italy
info@fanticmotor.it
fantic.com