

XEF 1.9 Race

Variante colore:
military green



Colore: **white**

Specifiche tecniche



Aluminum, sizes: S - M - L



Sram SX, 12V, 11-50



Brose S-Mag 36,
Torque/Coppia: 90 Nm



Magura MT7 4 Piston disc brake



Fantic, Lithium Ion, 36 Volt, 720Wh



Mavic E-Deemax 29" - 27.5"



RockShox Zeb Select 190mm



Vittoria E-Mazza
Vittoria E-Martello



RockShox SuperDeluxe Coil Select+



Selle Italia Model-X Bow Superflow

(*) FANTIC MOTOR si riserva il diritto di modificare le caratteristiche tecniche elencate, senza alcun obbligo di preavviso.
Tutte le immagini sono inserite a scopo illustrativo. I prodotti possono subire modifiche.



(*) FANTIC MOTOR si riserva il diritto di modificare le caratteristiche tecniche elencate, senza alcun obbligo di preavviso. Tutte le immagini sono inserite a scopo illustrativo. I prodotti possono subire modifiche.

XEF 1.9 Race

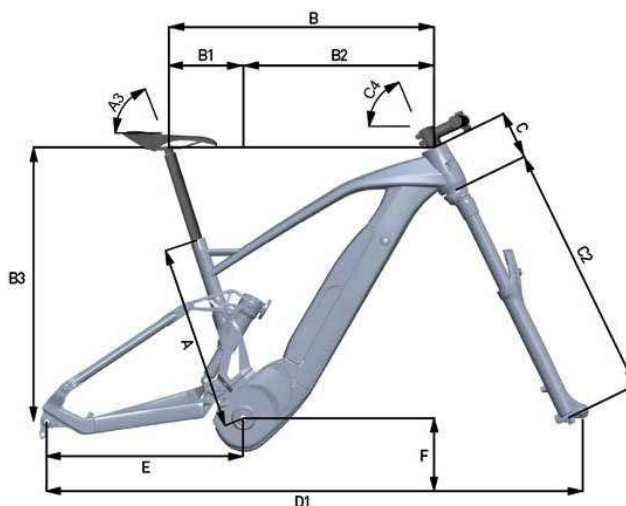

Motore	Brose S-Mag 36, Torque/Coppia: 90 Nm
Batteria	Fantic, Lithium Ion, 36 Volt, 720Wh
Display	Brose Remote
Telaio	Aluminum, sizes: S - M - L
Forcella (**)	RockShox Zeb Select 190mm
Ammortizzatore	RockShox SuperDeluxe Coil Select+
Corona	Sram 34t
Pedivelle	FSA
Deragliatore	Sram GX
Comandi cambio	Sram GX Eagle
Cassetta	Sram SX,12V, 11-50
Catena	Sram NX
Freno ant.	Magura MT7 4 Piston disc brake
Freno post.	Magura MT7 4 Piston disc brake
Disco ant.	Braking S3 Battfly, 220mm - 6Hole
Disco post.	Braking S3 Battfly, 203mm - 6Hole
Pneumatici ant.	Vittoria E-Mazza 29"x 2.6
Pneumatici post.	Vittoria E-Martello 27,5"x 2.8
Ruote	Mavic E-Deemax 29" - 27.5"
Manubrio	FSA Gradient-800mm- Ø35 - Rise 15mm
Attacco manubrio	FSA Gradient-35mm- Ø35 - Rise +6°
Reggisella	Crankbrothers HIGHLIGHT7 Ø 30.9 S-M, L
Sella	Selle Italia Model-X Bow Superflow
Note	(*)
(**) Alternative fork / forcella alternativa Suntour DuroLux 38 180mm	

Misure	S	M	L
A	390	430	490
A3	73	73	73
B	586	596	628
B1	161	162	166
B2	425	454	480
B3	617,8	622,0	633,7
C	105	110	120
C2	581	581	581
C4	65	65	65,5
D1	1241	1245	1270,5
E	459	459	459
F	363,5	363,5	363,5

(*) FANTIC MOTOR si riserva il diritto di modificare le caratteristiche tecniche elencate, senza alcun obbligo di preavviso. Tutte le immagini sono inserite a scopo illustrativo. I prodotti possono subire modifiche.



@fanticbikes



Fantic Bikes



Fantic Bikes



Fantic Motor



@fanticmotor_official

fantic.com

FANTIC

Fantic,
disegniamo,
progettiamo
ed assembliamo
bici elettriche
ad alte
prestazioni.

Fantic Motor S.P.A.
Via Tarantelli, 7
31030 Dossan di Casier (TV) Italy
info@fanticmotor.it
fantic.com