

Living City

Couleur: **white**

Fiches techniques



Aluminium, sizes: S - M - L

Promax Solve ST 925 hydraulic 2P,
180mm discYamaha PW S2,
Torque/Coppia: 75Nm

GBC 29" (M-L) - 27.5" (S)



Fantic, Lithium Ion, 36 Volt, 630Wh



Vittoria E-Randonneur



RST Volant, travel 50mm



Selle Italia T3 Flow

(*) FANTIC MOTOR se réserve le droit de modifier les caractéristiques techniques énumérées, sans aucune obligation de préavis.
Toutes les images sont incluses à des fins d'illustration. Les produits sont susceptibles d'être modifiés.



Index

Control, handling, exclusivity, mileage.

71

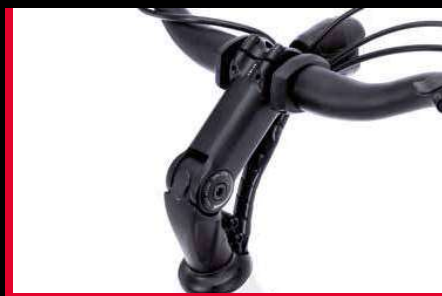

(*) FANTIC MOTOR se réserve le droit de modifier les caractéristiques techniques énumérées, sans aucune obligation de préavis. Toutes les images sont incluses à des fins d'illustration. Les produits sont susceptibles d'être modifiés.

Living City

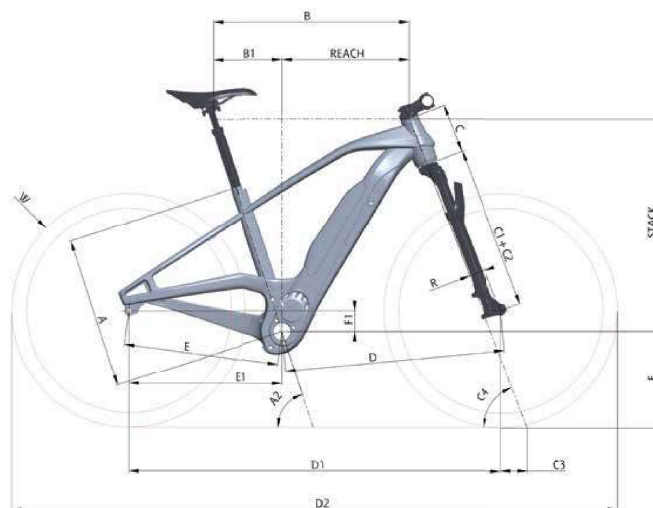

Moteur	Yamaha PW S2, Torque/Coppia: 75Nm
Batterie	Fantic, Lithium Ion, 36 Volt, 630Wh
Display	Display B Yamaha
Cadre & Tailles	Aluminium, sizes: S - M - L
Fourche	RST Volant, travel 50mm
Groupe	Enviolo City
Pédalier	FSA
Freins avant	Promax Solve ST 925 hydraulic 2P, 180mm disc
Freins arrière	Promax Solve ST 925 hydraulic 2P, 180mm disc
Pneus	Vittoria E-Randonneur
Jantes & Rayons	GBC 29" (M-L) - 27,5" (S)
Moyeux avt	GBC, 110mm Boost
Moyeux arr	GBC, 148mm Boost
Guidon	GBC 700mm, Rise 20mm
Potence	GBC 70mm
Selle	Selle Italia T3 Flow
Tige de selle	Promax Suspended Ø30,9
Pédales	Aluminium
Feu avant	Busch Muller
Feu arrière	Trelock
Cadenas	Abus
Annotation	(*)

Mesures	S	M	L
A	430	460	500
A2	72	72	72
B	575	600	625
B1	201	201	207
Reach	374	399	418
Stack	618	618	637
W	27,5"	28"	28"
C	150	150	170
C1	2	2	2
C2	460	460	460
C3 Trail	84,15	92,2	92,2
C4	69	69	69
R	44	44	44
D	637,5	662	688
D1	1101	1126	1152,5
D2	1785	1854	1880,5
E	471,2	471,2	471,2
E1	467	467	467
F	279	301	301
F1	63	63	63
Lever	170	170	170
Stem	100	100	100
Bar	700	700	700
Regg.	350	350	350

(*)FANTIC MOTOR se réserve le droit de modifier les caractéristiques techniques énumérées, sans aucune obligation de préavis.
Toutes les images sont incluses à des fins d'illustration. Les produits sont susceptibles d'être modifiés.



@fanticbikes



Fantic Bikes



Fantic Bikes



Fantic Motor



@fanticmotor_official

fantic.com

FANTIC

Fantic,
nous concevons,
réalisons et
assemblons
des vélos
électriques
à haute
performance.

Fantic Motor S.P.A.
Via Tarantelli, 7
31030 Dossan di Casier (TV) Italy
info@fanticmotor.it
fantic.com