

XTF 1.5 All Track

Farbvariante:
green



Farbe: **grey**

Technische Daten

Das Federbein aus "gespritztem Verbundwerkstoff"



Aluminum, sizes: S - M - L



Sram SX, 12V, 11-50



Yamaha PW X3,
Torque/Coppia: 85 Nm



Sram Level 2 Piston disc brake



Fantic, Lithium Ion, 36 Volt, 630Wh



Rodi TRYP30 - 29"



RockShox Recon Silver RL 150mm



Pirelli Scorpion ProWall Trail



RockShox Deluxe Select



Selle Italia MODEL-X
Comfort Superflow 145

(*) FANTIC MOTOR behält sich das Recht vor, technische Eigenschaften ohne vorherige Ankündigung zu ändern.
Änderungen der Produkte sind vorbehalten.



Index

Kontrolle, Handling, Exklusivität, Leistung.

21



(*) FANTIC MOTOR behält sich das Recht vor, technische Eigenschaften ohne vorherige Ankündigung zu ändern. Änderungen der Produkte sind vorbehalten.

XTF 1.5 All Track

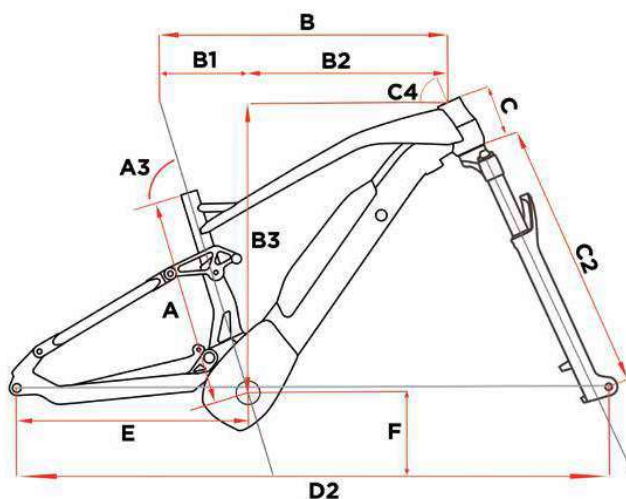

Motor	Yamaha PW X3, Torque/Coppia: 85 Nm
Batterie	Fantic, Lithium Ion, 36 Volt, 630Wh
Display	Yamaha Interface X
Rahmen	Aluminum, sizes: S - M - L
Gabel (**)	RockShox Recon Silver RL 150mm
Dämpfer	RockShox Deluxe Select
Kettenblätter	Sram 34t
Fahrrad kurbel	FSA
Schaltwerk	Sram SX
Schalthebel	Sram SX Eagle
Schaltkassette	Sram SX, 12V, 11-50
Kette	Sram SX
Bremse	Sram Level 2 Piston disc brake
Bremse	Sram Level 2 Piston disc brake
Bremsscheibe	SramCenterLine, 200mm - 6Hole
Bremsscheibe	SramCenterLine, 180mm - 6Hole
Reifen	Pirelli Scorpion ProWall Trail -M- 29"x 2.4
Reifen	Pirelli Scorpion ProWall Trail -R- 29"x 2.4
Felgen und Speichen	Rodi TRYP30 - 29"
Lenker	Promax-760mm-Rise 18mm-ø31,8
Vorbau	Promax-60mm-Rise+6°-ø31,8
Sattelstütze	RST ELEV8 A2 Ø 30.9, S - 80mm / M - 100mm / L - 125mm
Sattel	Selle Italia Model-X Comfort Superflow 145
Bemerkung	(*)
(**) Alternative fork / forcella alternativa Suntour Auron 35	

Maßnahmen	S	M	L
A	390	430	490
A3	73	73	73
B	575	602	627
B1	166	169	174
B2	407	433	453
B3	615,8	625,0	641,5
C	105	115	130
C2	567	567	567
C4	66	66	66,5
D1	1193	1224	1244
E	472	472	472
F	358	358	358

(*) FANTIC MOTOR behält sich das Recht vor, technische Eigenschaften ohne vorherige Ankündigung zu ändern. Änderungen der Produkte sind vorbehalten.



@fanticbikes



Fantic Bikes



Fantic Bikes



Fantic Motor



@fanticmotor_official

fantic.com

FANTIC

Fantic:
**Wir entwerfen,
entwickeln
und montieren
leistungsstarke
Elektrofahrräder.**

Fantic Motor S.P.A.
Via Tarantelli, 7
31030 Dossan di Casier (TV) **Italy**
info@fanticmotor.it
fantic.com